



SAVE-T® SCREEN-PRO™

Modular Door System For All Seasons



Door Configuration: In-Tube Motorized



TMI, LLC
5350 Campbells Run Road • Pittsburgh, PA 15205
Toll Free: 1-800-888-9750 • 412-787-9750 • Fax: 412-787-3665
Web: www.tmi-pvc.com • Email: info@tmi-pvc.com

Thank you for choosing TMI's Screen-Pro™

Before installing your new Screen-Pro™ door system, please inspect the contents of each package for shipping damage or missing hardware. If damage is discovered, prepare a claim against the freight provider.

Note: Any damage to the packaging of the product needs to be noted on shipping paperwork. If there is damage to any packaging, there may be damage to the product inside.

Do not install or operate this door until you have read and understood all instructions in the manual. If this is your first time installing a TMI Screen-Pro™, or if you have questions, please call 1-800-888-9750 before starting. We will be able to clarify any questions or concerns you may have.

Any unauthorized changes to these installation instructions or any changes to the parts, assemblies, or specification that are not authorized by TMI, LLC will void the product warranty.

Materials, Tools, and Equipment

It is recommended that two people install the door together. An Electrician is required for making all electrical connections.*

Have the following tools nearby for efficient installation.

- Carpenter's Level (Min. 4' Length)
- Carpenter's Square
- Hammer Drill
- Masonry Drill Bit (For 3/8" Diameter Anchors)
- 3/8" Diameter and Various Wall Anchors
- Assorted Shim Stock
- Socket and Wrench Set
- Hand Tools
- Four Bar Clamp (36" Long)
- Two Ladders
- Forklift (Supplied by Dealer or Customer)

(All electrical work needs to be performed in accordance with local and state building codes).

Screen-Pro™ General Door Arrangement

Below is the standard layout for the Screen-Pro™ with an In-Tube Motor Configuration.

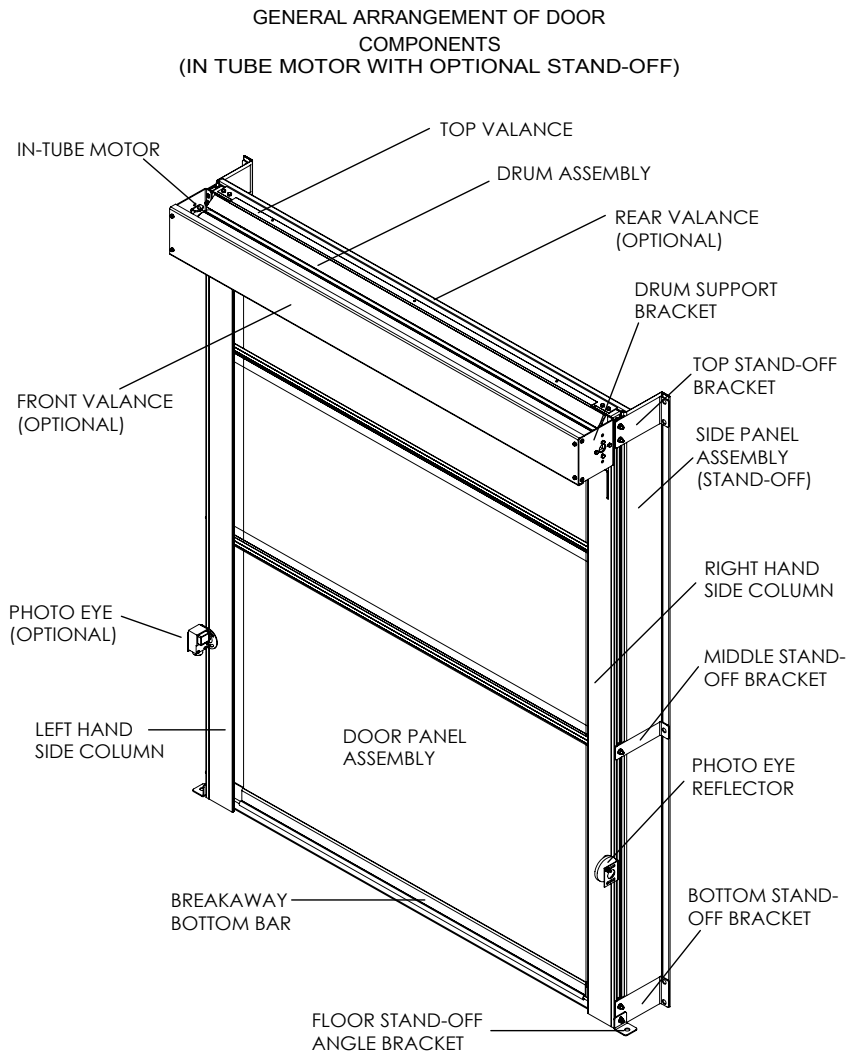

Installation of Guide Tracks

1. Lay the side columns on the floor.

The end of the track that has a section cut out is the “top” of the track. To determine “Left Hand” or “Right Hand” track, look for the gray vinyl flap on each track. Each vinyl flap should point toward the center of the door opening.

2. Attach the drum support brackets to the side columns. Attach the drum support bracket to each side column as shown below.



Left Side Guide Track



Right Side Guide Track

3. Set the Top Valance (steel angle) in between the side columns lying on the floor. The Top Valance has two holes drilled in each end, line these holes up with the holes in the Top Valance (small angle) that has been pre-attached to the Side Columns.

4. Measure the overall outside width of the side columns. This will give you an overall width of the door and will help you locate the spacing and placement of the Side Columns.



If your door is an In-Jamb mount, please skip steps 5 and 6 and proceed to step 6A. If your door is wall or inside stand-off mount, please continue with step 5.

Installation of Guide Tracks

5. Insert 5 bracket anchor plates and bolts into the large channel on the backside of the side columns.

Do this for both of the Side Columns (Left Hand side and Right Hand side). The thread of the bolt will attach to the Stand-Off Brackets in the next step.



Bracket Anchor Plate with Bolt (nut not shown)

6. Fasten the three brackets to the side column that will anchor the side column to the wall.

Top Stand-Off Bracket - located flush with the top of side column.

Middle Stand-Off Bracket - located halfway between the top and bottom Stand-Off brackets (shown below).

Bottom Stand-Off Bracket - located flush with bottom of the side column.

Note: If you have a Face of Wall Mount door, your brackets that mount the Side Columns will not have as long of a projection arm.

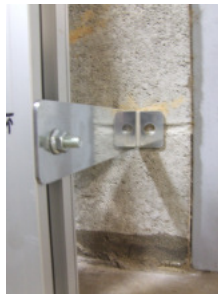

6A. Only applies to In-Jamb Mounting.

Attach the 1 1/2" x 1" Aluminum Angle to the backside of the side column (if there is sufficient Jamb spacing). If there is not adequate Jamb depth, this angle can be attached to the front side of the side column, towards the inside of the building. This angle can be attached to the Side Column using a self tapping screw.

7. Only applies to Inside Stand-Off mounting around existing door.

Insert the side panel (keder side) into the groove along the outside of the side column. The other side of the side panel is fastened to the wall using 1" aluminum flat bar. This aluminum flat bar should be anchored to the wall with the same anchors that hold the three "Stand-Off" Brackets to the wall in Step 6.

Installation of Guide Tracks and Side Panels

8. Stand the left side column up and find the location of the wall anchors that you will need. Once you determine these locations, do the following:

Inside Stand-Off Mount: First drill the aluminum flat bar and then drill the wall anchors.

Face of Wall Mount: Drill the wall anchors.

9. Fasten the side columns and side strips (if applicable) to the wall, but do not completely tighten anything yet. Adjustments need to be made later.

10. Once the side columns are mounted to the wall, attach the Top Valance (angle) across the top between the two side columns. This is the angle that was used in Step 2 to help determine overall width. This angle should bolt to the top of the Valance angles (already pre-attached to the side columns).

Installation of Door Barrel

11. Insert the barrel into the mounting brackets. Insert the Idler (non-motor) end first. When inserting the motor, use the white plastic bushing and clip to hold the motor in place.

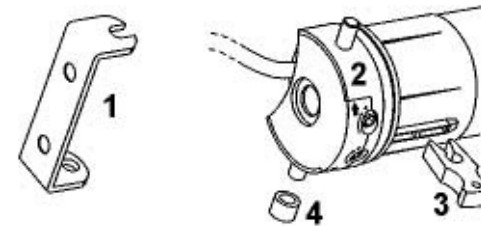

1. Motor Bracket

2. Motor Head

3. Clip

4. Bushing

Wiring the Motor and Setting the Door Limits

Wiring for one motor and one rocker switch

Power in	
Hot	Black
Neutral	White
Ground	Green
Motor Leads	
Direction 1	Red
Direction 2	Black
Neutral	White
Ground	Green

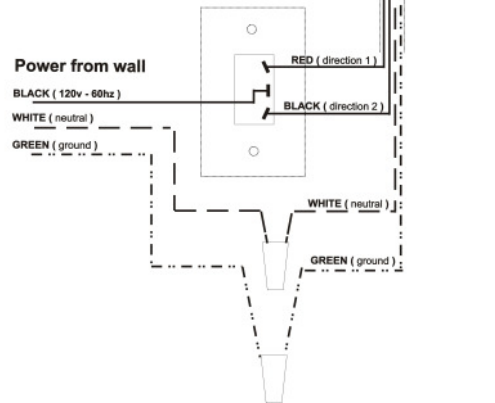

12. Set the up limit and the down limit. Use the enclosed black plastic tool to set the limits.

Note: When facing the limit switches on the motor, the switch on top sets the “Down/Lower” limit. The switch on the bottom sets the “Up/Top” limit. Material should roll off of the back side of barrel towards the wall.

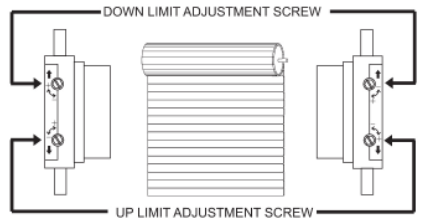

A. Identify which limit adjustment screw controls the “Up” limit and which controls the “Down” limit. It is important to note that the arrows by the limit adjustment screw refer to the drum rotation. The door panel comes off the tube on the back side and the limit adjustment faces the front of the door assembly.

B. Turning an adjustment screw clockwise will increase the maximum travel in the direction that it controls, and turning it counterclockwise will decrease the maximum travel.

C. To set a limit, run the motor in the selected direction.

Setting the Door Limits

D. If motor stops on its own before reaching the desired stop, turn the appropriate limit screw positive (clockwise). Every 3-4 turns of the limit adjustment screw equals approximately 1” of screen travel. After turning the limit adjustment screw, use the control switch to move the motor to the new limit position.

NOTE: If the motor does not stop on its own before reaching the desired limit, go to Step F.

E. When you are approximately at the desired limit position, use the control switch to run the motor away from the limit, 2’ to 3’ and then back. This will allow you to see precisely where the limits are set. Make small adjustments if required.

F. If the motor does not stop on its own at least 6” before the desired limit position, stop the motor with the control switch. Then turn the adjustment screw counterclockwise (negative) direction. Confirm that the motor is at the limit and set the limit as per Steps D & E. If the motor has not stopped at the limit, continue turning the screw counterclockwise (up to 120 turns may be needed).

NOTE: The motor has a built in thermal cutoff. If after several minutes of use the motor will not run in either direction, allow the motor to cool for approximately 20 minutes before using again.

Installing Brush Seal & Top Valance (Angle)

13. Install the brush seal to the top of the Valance (angle).

If you have a Face of Wall Mount door, you will attach the 45-degree retainer and brush to fill the gap at the top. However, if you have an Inside Stand-Off Door, you will have two separate brush seals. The 45-degree retainer will fill the gap from the Top Valance to the Screen Barrel. The “straight/flat” retainer will fill the gap from the Top Valance to the existing door. Both retainers use a 2” Brush.

14. Install the front Aluminum Valance.

Attach the front Aluminum Valance to the Drum Support Bracket and fasten to the front using two self tapping screws per side. Holes are pre-drilled in the Aluminum Valance.