

1 STANDARD UNIT DETAIL  
ISOMETRIC VIEW  
N.T.S.

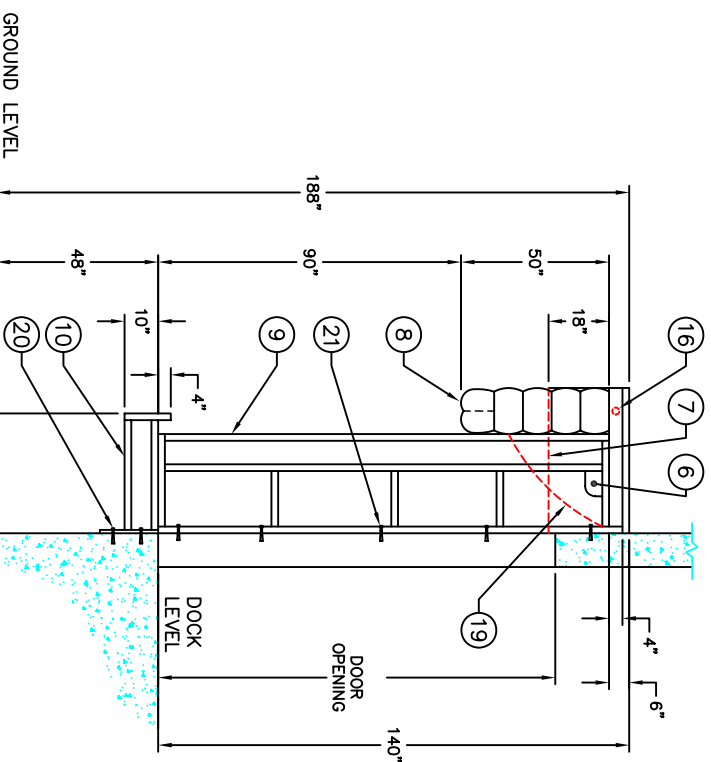

2 STANDARD UNIT DETAIL  
SIDE VIEW  
SCALE: 1" = 1'-0"

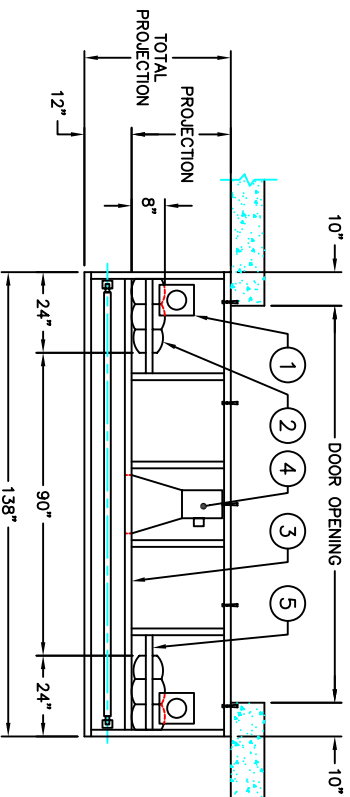

3 STANDARD UNIT DETAIL  
PLAN VIEW  
SCALE: 1" = 1'-0"

No.	DESCRIPTION
1	GALVANIZED AIR DUCT
2	VERTICAL AIR BAG
3	TORSION SPRING
4	0.5 HP, 1 Ph., 115/230 V, 50/60 Hz, 1420±1600 RPM, 5.5±2.8 A MOTOR / BLOWER
5	TRACK SUPPORT
6	AIR FLOW CONNECTION
7	STORAGE CURTAIN
8	HEADER AIR BAG
9	SIDE FRAME
10	STEEL GUARD
11	TRIM ANGLE - TOP
12	TRIM ANGLE - SIDE
13	STORAGE CURTAIN
14	REVERSE STOP SIGN (WHEN INFLATED)
15	BOTTOM PAD
16	TORSION SPRING EXTERIOR ADJUSTMENT
17	YELLOW GUIDE STRIPE
18	U.V. - 50 NATURAL POLYETHYLENE COVER
19	HEAD BAG STABILIZER
20	5/8" x 4.25" WEDGE ANCHOR
21	3/8" x 3" SLEEVE ANCHOR

STANDARD PROJECTIONS ARE:  
24", 30", 36" & 48"

NOTES: 1) ALL DIMENSIONS ARE STANDARD AND IN IMPERIAL SYSTEM.  
2) UNITS CAN BE MANUFACTURED TO SUIT.  
3) DRAWINGS NOT TO BE SCALED.

<b>LDC</b>	
SERIES	D450
TITLE	INFLATABLE TRUCK SHELTER
DISTRIBUTED BY	

REV.#	DATE	DESCRIPTION	BY
1			

DATE: 06/27/07	SHEET	OF	DWG.# D450	REV. 0
----------------	-------	----	------------	--------